

SIEMENS

SITRANS[®] P
pressure transmitter

Archivexemplar

7MF4020

Operating Instructions

Order No.: C73000—B5676—C71—3

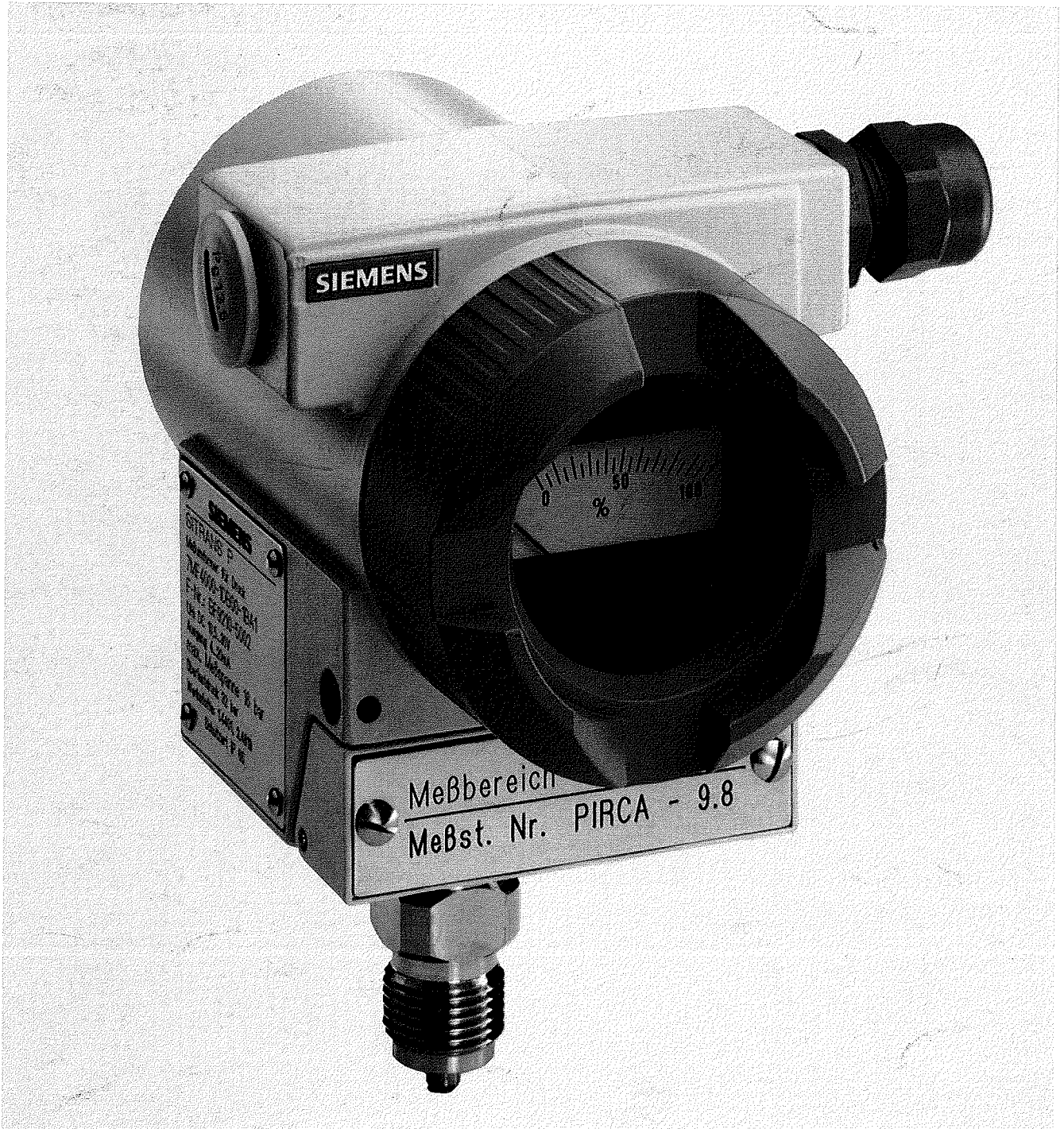

The reproduction, transmission or use of this document or its contents is not permitted without express written authority. Offenders will be liable for damages. All rights created by the granting of patents or registration of a design are reserved.

Technical data subject to change without notice.

© Siemens AG 1993

 **SIEMENS**

SITRANS P

pressure transmitter

 **7MF4020**

Operating Instructions

 **C73000-B5676-C71**

Contents

	Page
1 Technical description	6
1.1 Application	6
1.2 How it works	6
1.3 Technical data	7
1.4 Ordering data	10
1.5 Dimensions	11
2 Installation	12
2.1 Where to install	12
2.1.1 Fixing to the isolating valve	12
2.1.2 Fixing with a mounting bracket	13
2.2 Electrical connection	14
2.3 Installing the analogue indicator	15
3 Commissioning	16
4 Operation	18
4.1 General	18
4.2 Setting start of scale and full scale	21
4.2.1 Transmitter closed	21
4.2.2 Transmitter open	22
4.3 Setting start of scale and measuring span without a pressure source	23
4.4 Correction of zero point	24
4.5 Electrical damping	24
4.6 "Loop check" function	25
4.7 Output current in error situations	25
4.8 Disable pushbuttons	25
5 Maintenance	26
6 Conformance Certificate	27

Note

These instructions do not purport to cover all details or variations in equipment, nor to provide for every possible contingency that may arise during installation, operation or maintenance.

Should further information be desired or should particular problems arise that are not covered sufficiently for the Purchaser's purposes, the matter should be referred to the local Siemens Sales Office.

The contents of this instruction manual shall not become part of or modify any prior or existing agreement, commitment or relationship. The Sales Contract contains the entire obligations of Siemens. The warranty contained in the contract between the parties is the sole warranty of Siemens. Any statements contained herein do not create new warranties or modify the existing warranty.

**WARNING**

This equipment should only be installed and operated after qualified personnel have ensured that suitable power supplies are available. These personnel must ensure that the equipment is not subjected to any hazardous voltages during normal operation or when a defect occurs in the system.

This equipment may be used under high pressure and with aggressive media. Improper use of this equipment may therefore result in severe personal injury or extensive damage to property.

The successful and safe operation of this equipment is dependent upon its proper handling, installation, operation and maintenance.

Qualified person

For the purposes of this manual, a qualified person is one who is familiar with the installation, commissioning and operation of this equipment. In addition, the person must be:

- ☐ Trained and authorised to operate and service equipment/systems in accordance with established safety practices relating to electrical circuits, high pressures and aggressive media.
- ☐ Trained in the proper care and use of protective equipment in accordance with established safety practices.
- ☐ Trained in rendering first aid.

1 Technical description

1.1 Application

The SITRANS P transmitter measures the pressure of non-aggressive and aggressive gases, vapours and liquids. Measuring spans of between 0.1 and 400 bar are possible.

The output signal is a load-independent direct current 4 to 20 mA, linearly proportional to the measured pressure.

Transmitters of "intrinsically safe" design can be installed within hazardous areas (zone 1). The conformance certificate conforms to the European standard (CENELEC).

Transmitters fitted with various types of chemical seal are available for special applications, e.g. measuring highly viscous media.

1.2 How it works

Pressure is transmitted to a silicone pressure sensor (4, see Figure 1.1) through a diaphragm (2) and a liquid filling (3). The pressure causes the sensor's measuring diaphragm to distort. The resistance of four doped piezo-resistors in a bridge circuit in the measuring diaphragm changes. This change in resistance generates an output voltage in the bridge circuit that is proportional to the measured pressure. This voltage is converted into a periodic signal by an amplifier (11) in a voltage/frequency converter (12). A microcontroller (13) evaluates the signal, corrects it with respect to linearity and temperature before passing it on to a digital/analogue converter, which converts it into a 4 – 20 mA output current.

Data specific to the measuring cell and transmitter parameters are stored in non-volatile memory (EEPROM).

Transmitters with a measuring span of ≤ 63 bar measure pressure against atmosphere, those with spans of 160 bar and 400 bar against vacuum.

Calibration of the transmitter is performed using three pushbuttons located on the outside of the instrument. Settings are displayed on an LCD display inside the housing.

When the instrument is closed, start of scale and full scale can be set using a pressure source and the pushbuttons.

When the instrument is open, and the LCD visible, the following functions are available:

- set start of scale and full scale using pressure source
- set start of scale and measuring span without pressure source ("blind" calibration)
- electrical damping
- "loop check" function
- specify output current when errors occur
- disabling of pushbuttons when instrument closed

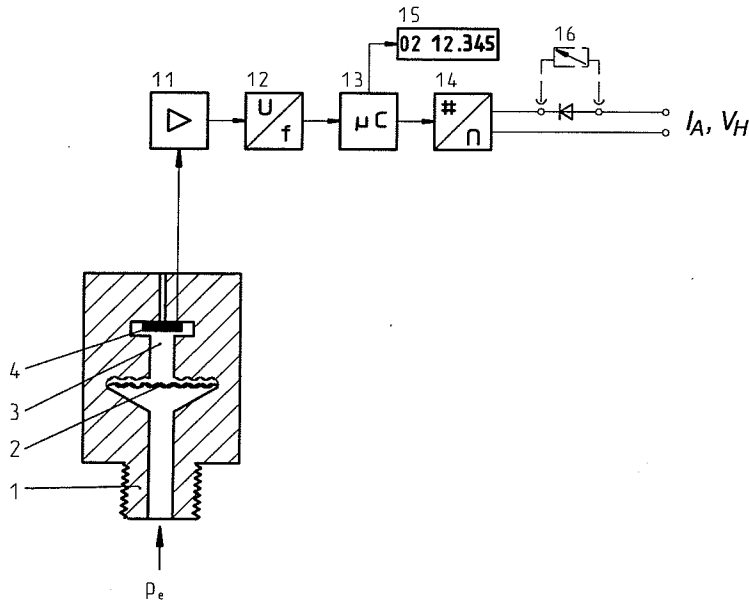

- I_A output current
- V_H auxiliary power
- p_e measured pressure
- 1 process connection
- 2 diaphragm
- 3 filling (liquid)
- 4 silicone pressure sensor
- 11 measuring amplifier
- 12 voltage/frequency converter
- 13 microcontroller
- 14 digital/analog converter
- 15 LCD
- 16 test sockets
- analogue indicator (option)

Figure 1.1 SITRANS P pressure transmitter, function diagram

1.3 Technical data

Functional data

Measuring spans and overrange limits

Variable measuring spans				Overrange limits	
				Lower	Upper
0.1 to 1 bar /	10 to 100 kPa	2)	6 bar		
0.4 to 4 bar /	40 to 400 kPa	2)	10 bar		
1.6 to 16 bar /	0.16 to 1.6 MPa	2)	32 bar		
6.3 to 63 bar /	0.63 to 6.3 MPa	2)	100 bar 1)		
16 to 160 bar ¹⁾ /	1.6 to 16 MPa ¹⁾	2)	250 bar 1)		
40 to 400 bar ¹⁾ /	4.0 to 40 MPa ¹⁾	2)	600 bar 1)		

Lower measuring limit

Measuring cell

- silicone oil filling
- Fluorolube filling

30 mbar (absolute)
atmospheric pressure

Upper measuring limit

100% of max. measuring span

Start of scale

anywhere between the measuring limits

Auxiliary power

terminal voltage on transmitter

11 to 45 V DC,
11 to 30 V DC in intrinsically-safe mode

Output signal

- lower limit
- upper limit
- in error situation
- ripple

4 to 20 mA
3.84 mA
22 mA
3.6 mA or 22.8 mA
 $I_{pp} \leq 0.5\%$ of maximum output current

Load

$$R \leq \frac{V_H - 11 \text{ V}}{0.023 \text{ A}} \text{ in } \Omega,$$

V_H : auxiliary power in V

1) With oxygen measurement Fluorolube filling, 80 bar max.
2) See lower measuring limit

Electrical damping variable time constant	0 to 2 s in steps of 0.1 s 2 to 100 s in steps of 1 s
Current source	3.6 mA, 4.0 mA, 12.0 mA, 20.0 mA or 22.8 mA
Ambient temperature	
Measuring cell filled with silicone oil	-40 °C to +85 °C
Fluorolube	-10 °C to +85 °C, observe temperature classes in hazardous areas!
Temperature of medium	
Measuring cell filled with silicone oil	-40 °C to +100 °C
Fluorolube	-10 °C to +100 °C
Storage temperature	-50 °C to +85 °C
Condensation	permitted
Installation	process connection pointing vertically down
Response characteristic	
with rising characteristic, start of scale 0 bar and filling of silicone oil. All figures relate to the output span.	
Measurement error when calibrating fixed point (incl. hysteresis and repeatability)	≤ 0.1 %
Time constant T_{63} at 20 °C (no electrical damping)	approx. 0.2 s
Long-term drift	≤ 0.1% every 6 months at max. measuring span
Effect of ambient temperature	
on start of scale	
from -10 °C to +60 °C	≤ 0.05 %/10 K at max. measuring span
from -40 °C to -10 °C and +60 °C to +85 °C	≤ 0.1 %/10 K at max. measuring span
on measuring span	
from -10 °C to +60 °C	≤ 0.1 %/10 K
from -40 °C to -10 °C and +60 °C to +85 °C	≤ 0.15 %/10 K
Effect of auxiliary power	≤ 0.005 % for each 1 V change in voltage
Electro-magnetic compatibility	conforms to IEC 801/NAMUR recommendations
Effect of installation from vertical	≤ 0.05 mbar / per 10° deviation

Instrument design

Electrical connection	screw-type terminals or Han 7D connector Cable inlet in the case of screw-type terminals via Pg 13.5 compression gland or M20 x1.5 female thread or ½ – 14 NPT female thread
Degree of protection to EN 60529	IP65
Process connection	connecting shank G ½A conforming to DIN 16288 or ½ – 14 NPT female thread
Material of components that come into contact with the medium	
connecting shank	stainless steel, material no. 1.4401
diaphragm	stainless steel, material no. 1.4404 or Hastelloy C276, material no. 2.4819
Measuring cell filling	silicone oil or Fluorolube
Housing for electronics	die-cast aluminium with low copper content GD-AISi 12, polyester based lacquer, stainless steel rating plate
Mounting bracket (optional)	galvanised, yellow-passivated steel, or stainless steel
Analogue indicator (optional)	linear scale 0 to 100% or to customer's specification
Weight	approx. 1.5 kg (without options)
Explosion protection	
to DIN EN 50014 and DIN EN 50020 (CENELEC)	
Type of protection	intrinsically safe "i" EEx ia IIC T4 or T5 or T6
Conformance certificate	PTB Ex-92.C.2146
Max. ambient temperature	+85 °C (temperature class T4) +75 °C (temperature class T5) +60 °C (temperature class T6)
Connection	to certified intrinsically safe circuits with the following maximum values: $V_o = 30 \text{ V}$, $I_K = 100 \text{ mA}$, $P = 750 \text{ mW}$
Effective internal inductance	$L_i \leq 0.6 \text{ mH}$
Effective internal capacitance	$C_i \leq 6 \text{ nF}$

1.4 Ordering data

Description		Order no.
SITRANS P pressure transmitter 2-wire system		7MF4020 - <input type="checkbox"/> <input type="checkbox"/> <input type="checkbox"/> <input type="checkbox"/> - 1 <input type="checkbox"/> <input type="checkbox"/> <input type="checkbox"/>
Measuring cell filling	Cleaning of measuring cell	
Silicone oil Fluorolube ¹⁾	Normal Greasefree	
<u>Measuring span</u>		
0.1 bar to	1 bar	
0.4 bar to	4 bar	
1.6 bar to	16 bar	
6.3 bar to	63 bar	
16 bar to	160 bar ¹⁾	
40 bar to	400 bar ¹⁾	
<u>Material of components that come into contact with the medium</u>		
Diaphragm	Connecting shank	
Stainless steel	Stainless steel	A
Hastelloy	Stainless steel	B
Version with chemical seal		Y
<u>Process connection</u>		
Connecting shank	G 1/2 A	00
Female thread	1/2-14 NPT	10
<u>Explosion protection</u>		
none		A
intrinsically safe		B
<u>Electrical connection/cable inlets</u>		
Pg 13.5 compression gland		A
Female thread M20 x 1.5		B
Female thread 1/2-14 NPT		C
Han 7D connector		D
<u>Indicator</u>		
none		1
with analogue indicator		
scale 0 to 100%, linear		3
scale as specified (Y20 code required)		5

Other versions
Add "-Z" suffix and code to order no.

Additional information
Add "-Z" suffix and code to order no. and specify in writing

Description	Code
Transmitter with mounting bracket of steel	A01
stainless steel	A02
<hr/>	
Operating instructions and description of the plate (German by default)	
English	B11
French	B12
Spanish	B13
Italian	B14
<hr/>	
Manufacturer's test certificate M as specified in DIN 55350, Part 18 and ISO 8402	C11
Acceptance certificate B as specified in DIN 50049, section 3.1, and EN 10204	C12

Description	Code
Required measuring range (max. 26 characters), specify in plain text, Y01: ... to ... mbar, bar, kPa, MPa, ...	Y01
<hr/>	
Measuring point number/description (max. 16 characters), specify in plain text: Y15:	Y15
<hr/>	
Measuring point message (max. 27 characters), specify in plain text: Y16:	Y16
<hr/>	
Customer specified scale for analogue indicator (max. 26 characters), specify in plain text: Y20: ... to ... mbar, bar, kPa, MPa, ...	Y20

¹⁾ With oxygen measurement Fluorolube filling, 80 bar max.

1.5 Dimensions

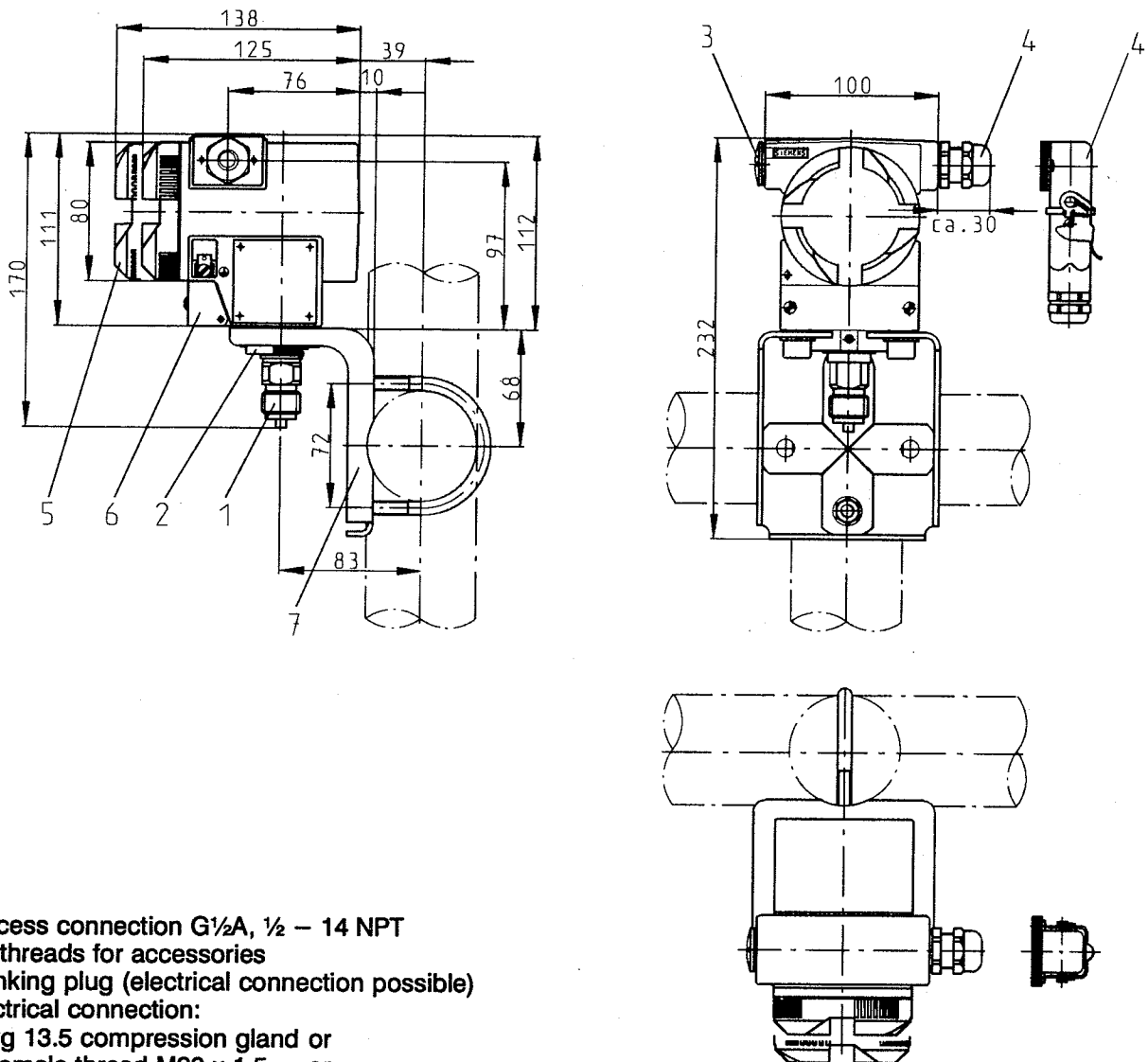

- 1 Process connection $G\frac{1}{2}A$, $\frac{1}{2} - 14$ NPT
- 2 M8 threads for accessories
- 3 Blanking plug (electrical connection possible)
- 4 Electrical connection:
Pg 13.5 compression gland or
Female thread M20 x 1.5 or
Female thread $\frac{1}{2}-14$ NPT or
Han 7D connector
- 5 Indicator (optional)
- 6 Protective cover for keyboard
- 7 Mounting bracket (optional), with U-bolt for fixing
to vertical or horizontal pipe
(50 to 60 mm in diameter)

Figure 1.2 SITRANS P pressure transmitter, dimensions

2 Installation

2.1 Where to install

The transmitter can be installed above or below the pressure tapping point. When measuring gases, we recommend the transmitter be installed above the pressure tapping point and the pressure pipe be laid so it runs down to the pressure tap. This will permit any condensation in the pipe to drain off and not affect the measurement. When measuring liquids, the transmitter should be installed below the pressure tapping point and the pipe laid so it rises up to the pressure tap, thus enabling any gas in the pipe to be dispersed.

The point of installation should be easily accessible, preferably close to the measuring point and free from vibration. The permitted ambient temperature limits must not be violated. Protect the transmitter from direct heat sources. Before installing the transmitter, compare the process data against the data on the rating plate. Keep the transmitter closed during the installation process.

The transmitter can be fixed to the isolating valve or secured with the mounting plate, depending on the type of process connection.

Note: The measuring cell must not be rotated within the electronics housing!

2.1.1 Fixing to the isolating valve

In the installation example in Figure 2.1, the SITRANS P transmitter is screwed onto a DIN 16720 model B isolating valve. The isolating valve is fixed to a wall or pipe by a clamp.

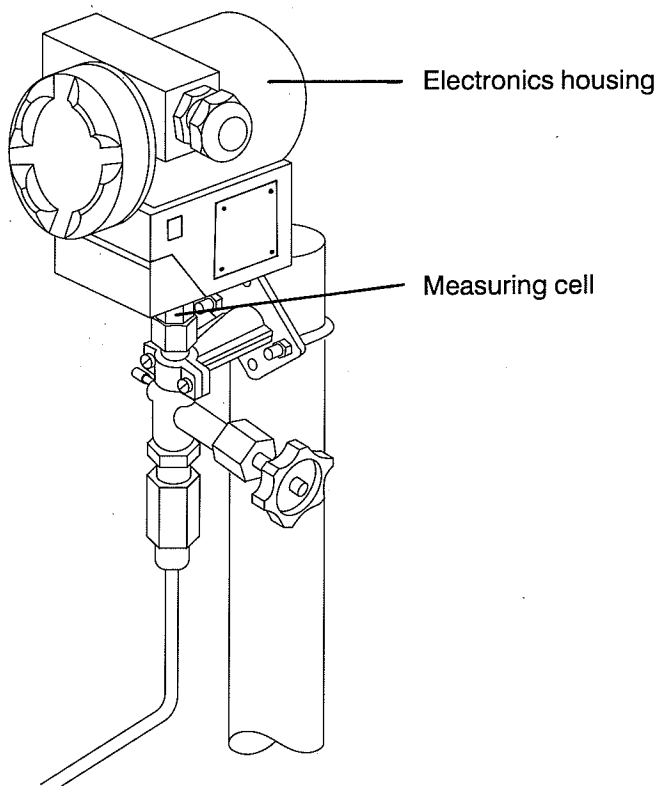

Figure 2.1

Fixing SITRANS P to a isolating valve using G1/2A connecting shank

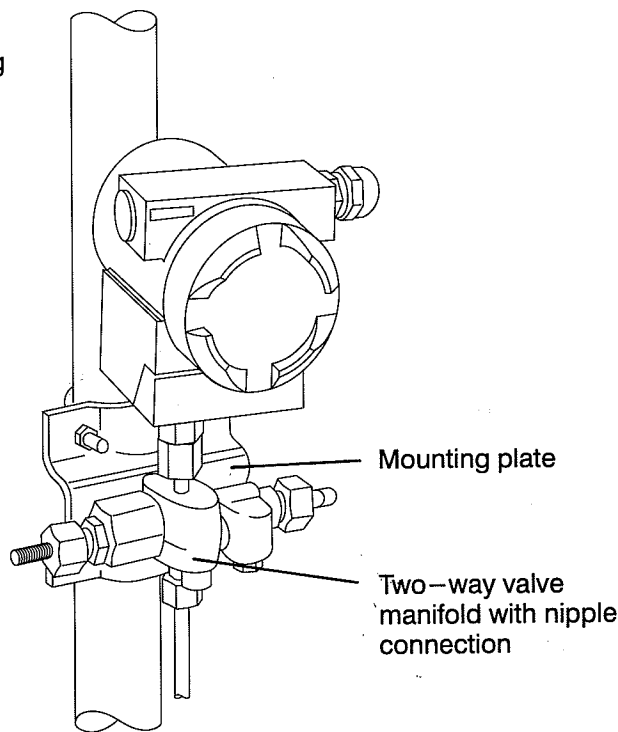

Figure 2.2

Figure 2.2 shows SITRANS P screwed to a two-way valve manifold with a welded nipple connection. The two-way valve manifold is fastened using a mounting plate.

2.1.2 Fixing with a mounting bracket

The mounting bracket is fixed to either

- a wall or mounting frame using 2 screws, or
- to a vertical or horizontal mounting pipe (50 to 60 mm in diameter) using a U-bolt.

The transmitter is fastened to the mounting bracket using the two enclosed M8 x 20 screws.

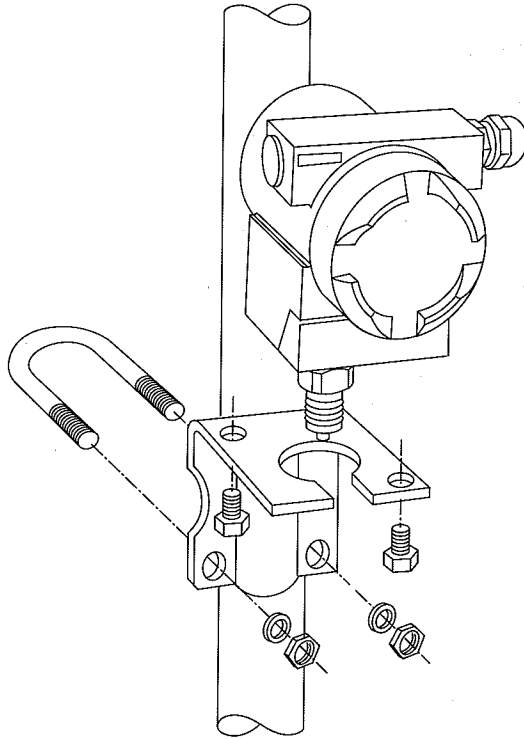

Figure 2.3 Fixing the SITRANS P transmitter using a mounting bracket

2.2 Electrical connection



WARNING

Observe the relevant regulations during the electrical installation; in hazardous areas, pay particular attention to:

- ☞ the regulations governing electrical systems in hazardous areas (Elex V)
- ☞ the specifications regarding the installation of electrical systems in hazardous areas (VDE 0165) and
- ☞ the conformance certificate

Check that the auxiliary power supply matches that specified on the rating plate.

The transmitter should be powered from a SELV (safety extra-low voltage) source. If other power sources are to be used, we recommend that the transmitter housing be earthed. The earth terminal in the terminal housing is galvanically connected to the external earth terminal.

☐ The following general guidelines apply when laying terminal (cross section 1.5 mm² max.)/signal cables:

- lay the signal cable separately from cables carrying voltages > 60 V
- use twisted-pair cables
- do not lay the cables close to large electrical systems, or use screened cable

☐ Connection to screw-type terminals

- remove housing cover
- remove analogue indicator (if fitted)
- feed cable in through cable gland
- connect to "+" and "-" terminals, observing polarity!
- replace analogue indicator (if applicable)
- replace transmitter cover

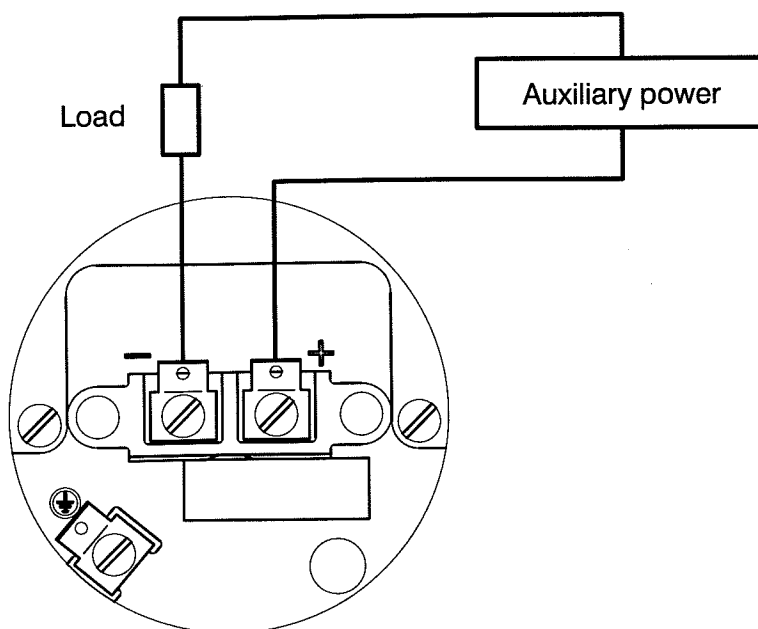

Figure 2.4 Electrical connection schematic

Connection using a plug connector

The contacts for the connector are supplied in a bag with the instrument.

- slide sleeve and gland on to the cable
- remove about 8 mm of insulation from the end of the cable
- crimp or solder the contacts to the cable ends
- assemble connector

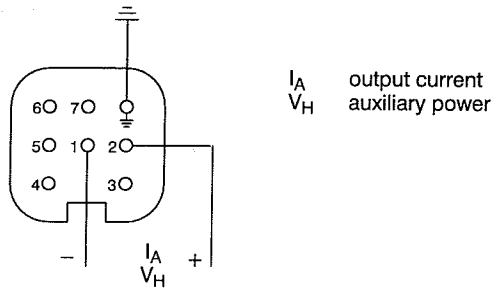

Figure 2.5 Connection using plug connector

2.3 Installing the analogue indicator

- Remove transmitter cover
- Plug analogue indicator into the test sockets
- Replace cover and viewing window

3 Commissioning

The process data must correspond to that on the rating plate. The transmitter functions as soon as the power is turned on.



WARNING

Severe personal injury or damage to property may result if the valves are improperly or incorrectly operated.

Measuring gases

The isolating valves should be operated in the following sequence:

Initial setting: all valves closed

- Open isolating valve (2B),
- Apply a pressure corresponding to the start of scale to the transmitter (1) using the test connection of isolating valve (2),
- Check the start of scale and correct if necessary (see section 4.2),
- Close isolating valve (2B),
- Open isolating valve (4) at pressure tapping point,
- Open isolating valve (2A).

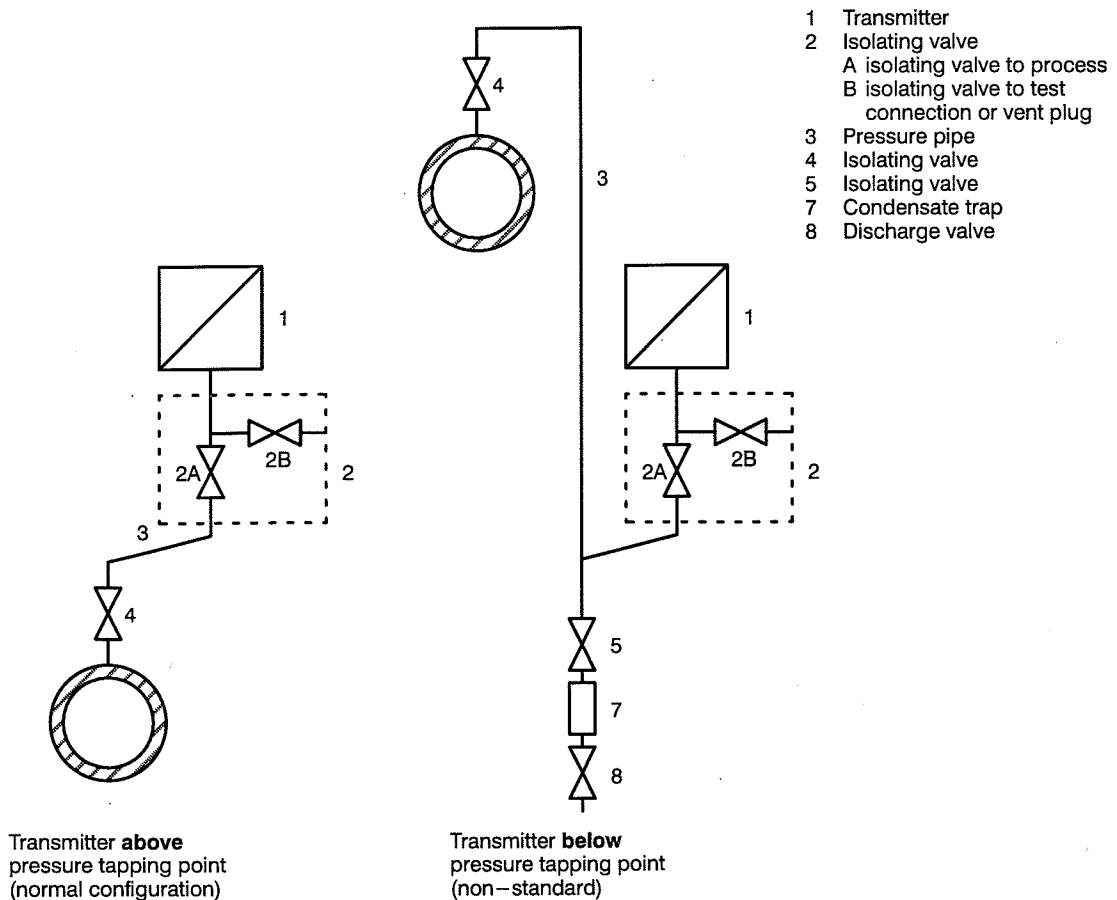

Figure 3.1 Measuring gases

Measuring liquids

The isolating valves should be operated in the following sequence:

Initial setting: all valves closed

- Open isolating valve (2B),
- Apply a pressure corresponding to the start of scale to the transmitter (1) using the test connection of isolating valve (2),
- Check the start of scale and correct if necessary (see section 4.2),
- Close isolating valve (2B),
- Open isolating valve (4) at pressure tapping point,
- Open isolating valve (2A).

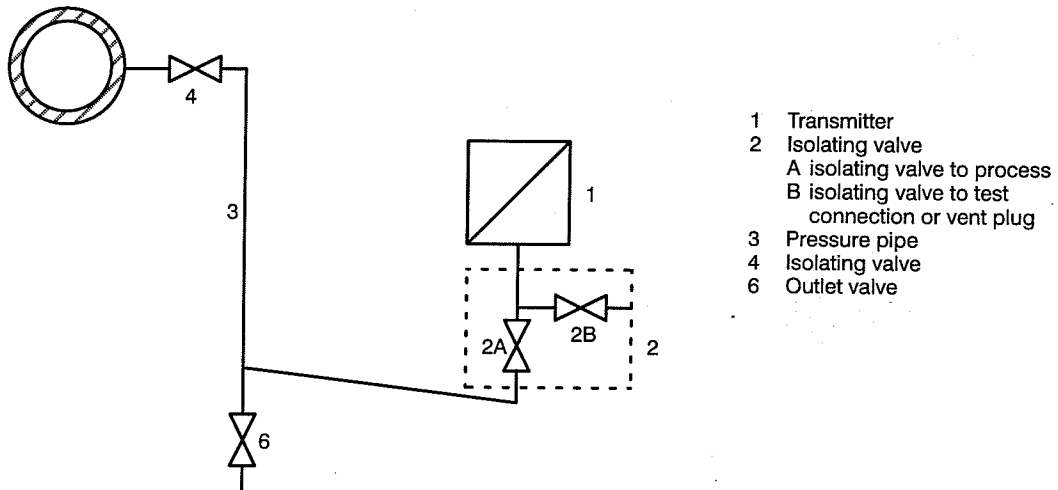

Figure 3.2 Measuring liquids

Measuring steam

The isolating valves should be operated in the following sequence:

Initial setting: all valves closed

- Open isolating valve (2B),
- Apply a pressure corresponding to the start of scale to the transmitter (1) using the test connection of isolating valve (2),
- Check the start of scale and correct if necessary (see section 4.2),
- Close isolating valve (2B),
- Open isolating valve (4) at pressure tapping point,
- Open isolating valve (2A).

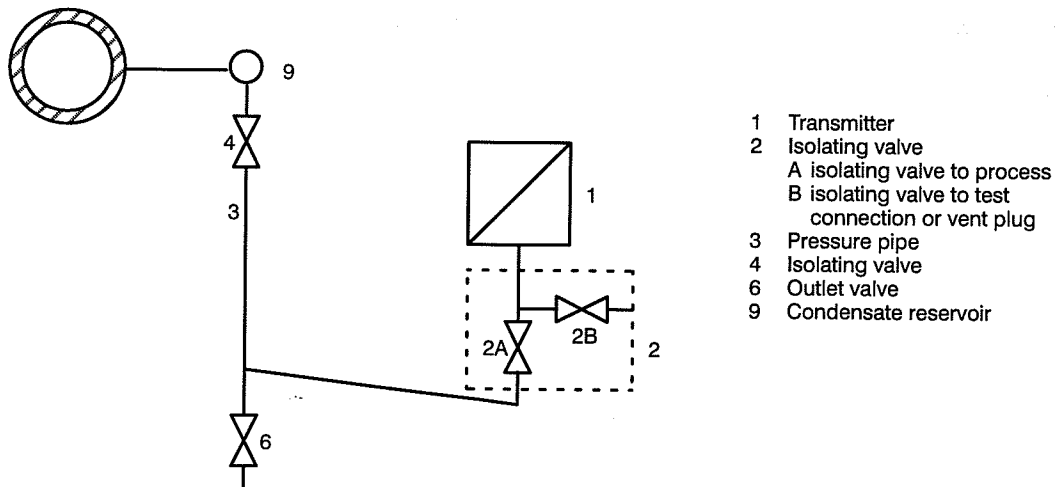

Figure 3.3 Measuring vapours

4 Operation

4.1 General

The SITRANS P pressure transmitter is easily parameterised in the field without having to use auxiliary instruments, such as a hand-held terminal.

The transmitter is operated by three pushbuttons located on the outside of the instrument. Settings are displayed on an LCD located inside the housing. The pushbuttons can be accessed by undoing the two screws holding the protective cover in place, which can then be moved out of the way.

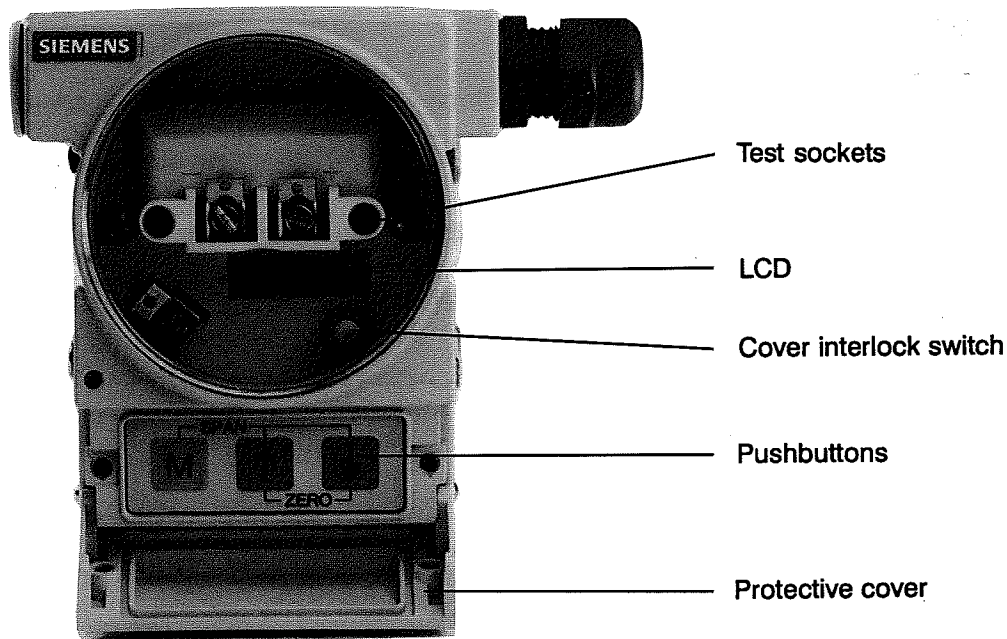

Figure 4.1 SITRANS P transmitter controls and displays

There are two ways of operating the transmitter:

- **With the transmitter closed**
Only able to set start of scale and full scale
- **With the transmitter open**
All functions available (see Table 4.1)

With the transmitter open, functions are selected using the **[M]** key and indicated by a mode number on the LCD. The mode number can be modified using the **[↑]** and **[↓]** keys. The LCD always displays the current value.

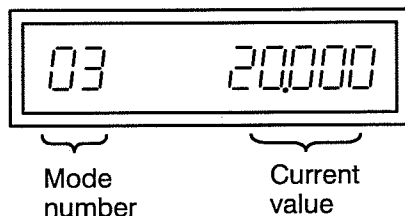

Figure 4.2 Liquid Crystal Display

General notes

- Clean the transmitter before opening it to prevent the ingress of dirt
- Remove the analog indicator (if fitted) to view the LCD
- For all modes (except 07 and 08) applies to:
An adjusted value will only be stored, when the mode is changed or the transmitter reverts to the "Measured value" function.
- The transmitter reverts to the "Measured value" function:
 - if mode 10 is passed by pressing the **M** key
 - if 2 minutes elapse without a key being pressed (except in mode 08: "loop check")
 - if the cover interlock switch is pressed
 - when the transmitter is closed
- On completion of calibration
 - replace the analogue indicator in the test sockets (if applicable)
 - screw cover back on
 - replace protective cover and tighten both screws

Function	Mode	Key			Display, Description	Section
		↑	↓	↑ a. ↓ ¹⁾		
Measured value					Output current in mA 3.84 to 22	
	E				Output current 22.8 or 3.6 mA "E" indicates error	
Status	01				0 : OK ≠ 0 : Error	
Start of scale	02	increase	decrease	set to 4 mA ²⁾	Output current in mA	4.2.2
Full scale	03	increase	decrease	set to 20 mA ²⁾	Output current in mA	4.2.2
Electrical damping	04	increase	decrease		Time constant T ₆₃ in s Range: 0.0 to 1.9; 2 to 100	4.5
Start of scale "blind" calibration	05	increase	decrease		Start of scale as percentage of max. measuring span	4.3
Measuring span "blind" calibration	06	increase	decrease		Measuring span as percentage of max. measuring span	4.3
Set zero point "blind" calibration	07	---	--	execute	Calibrate pressure to atmosphere The calibrated value will be displayed as percentage of the max. measuring span. (Start of scale does not change)	4.4
"Loop check" function	08	increase	decrease	initiate	Constant output current in mA 3.6 4.0 12.0 20.0 22.8 Terminate using [M] key or cover interlock switch	4.6
Output current in error situation	09	toggles between the two values			Selected output current Either 22.8 or 3.6 mA	4.7
Disable pushbuttons	10	increase	decrease		Pushbutton operation with transmitter closed 0 = start of scale and full scale 1 = start of scale only 2 = none	4.8

1) Press **↑** and **↓** keys simultaneously for about 2 s. The display goes blank and the current value is displayed after about 2 s.

2) If **┌-----** or **└-----** is displayed, the measuring range limits have been violated.

Table 4.1 SITRANS P transmitter functions

4.2 Setting start of scale and full scale

There are two ways of setting the start of scale and full scale values:

- with the transmitter closed
- with the transmitter open

Note: The start of scale and measuring span are non-interactive.
(Measuring span = full scale – start of scale)

4.2.1 Transmitter closed



Note: Pushbuttons may be disabled! See Table 4.1, mode 10.

- Undo the two screws holding the protective cover in place, which can then be moved out of the way

Set start of scale (4 mA) and full scale (20 mA)

Assuming the pushbuttons are pressed as described below, the transmitter sets the start of scale to 4 mA and the full scale to 20 mA. An ammeter is not required.

Start of scale

- Apply a pressure corresponding to the start of scale to the transmitter. When the start of scale is 0 bar, ensure the measuring chamber is equal to atmospheric pressure.
- Press  and  keys together for about 2 s

Full scale

- Apply a pressure corresponding to the full scale to the transmitter
- Press all three keys, making sure you press the  key first and release it last, otherwise the start of scale may be incorrect; set start of scale and full scale again if necessary

Calibrate start of scale and full scale

If the output current is going to be variable rather than fixed:



- connect a DC meter to the output circuit







WARNING

If the transmitter is installed in a Zone 1 hazardous area, use a passive DC meter only.

Start of scale

- Apply a pressure corresponding to the start of scale to the transmitter. When the start of scale is 0 bar, ensure the measuring chamber is equal to atmospheric pressure.
- Set the output current for start of scale using the  and  keys

Full scale

- Apply a pressure corresponding to the full scale to the transmitter
- Set the output current for full scale using the  key **and** the  key or the  key **and** the  key. Always press the  key first and release it last, otherwise the start of scale may be incorrect; set start of scale and full scale again if necessary and recalibrate.

4.2.2 Transmitter open

Read the general notes in section 4.1.

Note: If no pressure source is available,

the start of scale can be set in mode 05 and
the measuring span in mode 06.

Both are specified as a percentage of the maximum measuring span, see section 4.3.

Set start of scale

– Apply a pressure corresponding to the start of scale to the transmitter. Compensate the pressure for atmosphere when the start of scale is 0 bar.

– Select mode 02 using the **[M]** key

– Set the output current corresponding to the start of scale using the **↑** and **↓** keys

or

Set output current to 4 mA:

– Press the **↑** and **↓** keys simultaneously for about 2 s

If **┌L _ _ _** or **└┐ _ _ _** is displayed, the measuring range limits have been violated.
The original value remains unchanged.

Set full scale

– Select mode 03 using the **[M]** key.

– Apply a pressure corresponding to the full scale to the transmitter.

– Set the output current corresponding to full scale using the **↑** and **↓** keys.

or

Set output current to 20 mA:

– Press the **↑** and **↓** keys simultaneously for about 2 s

If **┌L _ _ _** or **└┐ _ _ _** is displayed, the measuring range limits have been violated.
The original value remains **unchanged**.

4.3 Setting start of scale and measuring span without a pressure source

Performed with transmitter open, observe the general notes in section 4.1.

It is possible to set the start of scale and measuring span of the SITRANS P transmitter even if there is no pressure line connected or pressure source available ("blind" calibration).

To set start of scale

- Select mode 05 using the **[M]** key
- Use the **[↑]** or **[↓]** key to set the start of scale as a percentage of the maximum measuring span

To set the measuring span

- Select mode 06 using the **[M]** key
- Use the **[↑]** or **[↓]** key to set the measuring span as a percentage of the maximum measuring span

Example 1

A transmitter with a maximum measuring span of 16 bar is to be calibrated to a measuring range of 0 to 12 bar to correspond to 4 to 20 mA.

The start of scale 0 bar corresponds to 0% of the measuring span and the measuring span 12 bar to 75% of the maximum measuring span.

- For the start of scale, set the value "0.00" in mode 05
- For the measuring span, set the value "75.00" in mode 06

Example 2

A transmitter with a maximum measuring span of 1 bar is to be calibrated to a measuring range of -0.1 to $+0.4$ bar to correspond to 4 to 20 mA.

The start of scale -0.1 bar corresponds to -10% of the measuring span and the measuring span 0.5 bar (full scale minus start of scale) to 50% of the maximum measuring span.

- For the start of scale, set the value " -10.00 " in mode 05
- For the measuring span, set the value " 50.00 " in mode 06

4.4 Correction of zero point

Performed with transmitter open, observe the general notes in section 4.1.

If the transmitter is installed and operational, external influences such as angle of installation, ambient temperature, or installation dependent pressure effects (e.g. head of liquid in the impulse pipe line to the transmitter) may cause an offset in the transmitter's zero point. This offset can be corrected in the SITRANS P transmitter without modifying the start of scale and span settings in modes 05 and 06 (correction of zero point).

- Compensate the pressure for atmosphere
- Select mode 07 using the **[M]** key
- Press the **[↑]** and **[↓]** keys simultaneously for about 2 s

The zero point correction is displayed as a percentage of the maximum measuring span.

Example

A transmitter with a maximum measuring span of 1 bar is calibrated for a measuring range of 200 to 800 mbar (4 to 20 mA), i.e. start of scale 20% ($\hat{=}$ 200 mbar) in mode 05, measuring span 60% ($\hat{=}$ 600 mbar) in mode 06. The transmitter is, however, being used in hotter conditions, which is causing an offset in the original zero point.

This offset is to be corrected.

- Ensure the measuring chamber is equal to atmospheric pressure
- Press the **[↑]** and **[↓]** keys simultaneously for about 2 s in mode 07. A value of "–0.22", for example, is displayed, which means that the zero point has been corrected by –0.22%.

The start of scale and measuring span of 20% and 60% set in modes 05 and 06 respectively remain unchanged.

4.5 Electrical damping

Performed with transmitter open, observe the general notes in section 4.1.

Note: The time response of the SITRANS P transmitter is determined by the time constant T_{63} (see section 1.3) and the electrical damping value.

The SITRANS P transmitter is supplied with a damping value of 0.0 s. Values of

0.0 to 2 s in increments of 0.1 s and

2 to 100 s in increments of 1 s

are permitted.

- Select mode 04 using the **[M]** key
- Use the **[↑]** and **[↓]** keys to change the damping value

4.6 "Loop check" function

Performed with transmitter open, observe the general notes in section 4.1.

The following output current constants can be set to check the output signal loop, e.g. during commissioning, irrespective of the pressure:

3.6 mA
4.0 mA
12.0 mA
20.0 mA
22.8 mA

- Select mode 08 using the **[M]** key
- Press the **[↑]** and **[↓]** keys simultaneously for about 2 s. This activates the "loop check" function. An output current of 4.0 mA is displayed.
- Use the **[↑]** and **[↓]** keys to select the required current

Changing the mode or pressing the cover interlock switch or closing the transmitter disables the "loop check" function.

4.7 Output current in error situations

Performed with transmitter open, observe the general notes in section 4.1.

The pressure sensor and electronics are monitored continuously. If a defect occurs, the output current is displayed as 3.6 or 22.8 mA, neither of which are possible under normal conditions. Which value is displayed is determined using mode 09. The factory setting is 22.8 mA.

- Select mode 09 using the **[M]** key
- Use the **[↑]** or **[↓]** key to select either 3.6 mA or 22.8 mA

Changing the mode or pressing the cover interlock switch or closing the transmitter causes the selected value to be stored.

4.8 Disable pushbuttons

Performed with transmitter open, observe the general notes in section 4.1.

The pushbuttons located under the protective cover can be protected against accidental or unauthorised use **when the transmitter is closed.**

- Select mode 10 using the **[M]** key
 - Use the **[↑]** or **[↓]** key to select either 0, 1 or 2
- 0 → start of scale and full scale can be altered
- 1 → start of scale only can be altered
- 2 → all pushbuttons disabled

Changing the mode or pressing the cover interlock switch or closing the transmitter causes the selected value to be stored.

5 Maintenance

The transmitter requires no maintenance.

Check the transmitter's start of scale value occasionally (see section 4.2 or 4.3).

The output current is displayed on the LCD. If an error has occurred, the character "E" is displayed in the first position.

6 Conformance Certificate

Physikalisch-Technische Bundesanstalt



KONFORMITÄTSBESCHEINIGUNG

PTB Nr. Ex-92.C.2146

- (1)
- (2)
- (3) Diese Bescheinigung gilt für das Meßumformer SITRANS P Typ 7MF4***-****-1B+*
- (4) der Firma Siemens AG, 300000 Kapfenberg
- (5) Die Bauart dieses elektrischen Betriebsmittels sowie die verschiedenen zulässigen Ausführungen sind in der Anlage zu dieser Konformitätsbescheinigung festgelegt.
- (6) Die Physikalisch-Technische Bundesanstalt bescheinigt als Prüfstelle nach Artikel 14 der Richtlinie des Rates der Europäischen Gemeinschaften vom 18. Dezember 1975 (76/117/EWG) die Übereinstimmung des elektrischen Betriebsmittels mit den harmonisierten Europäischen Normen
Elektrische Betriebsmittel für explosionsgefährdete Bereiche
EN 504014:1977 + A1 (VDE 0170/0171 Teil 1) Allgemeine Bestimmungen
EN 504020:1977 + A2 (VDE 0170/0171 Teil 2) Eigensicherheit
- nachdem das Betriebsmittel mit Erfolg einer Bauartprüfung unterworfen wurde. Die Ergebnisse dieser Bauartprüfung sind in einem Prüfprotokoll festgelegt.
- (7) Das Betriebsmittel ist mit dem folgenden Kennzeichen zu versehen:
EEx ia IIC T6
- (8) Der Hersteller ist dafür verantwortlich, daß jedes derart gekennzeichnete Betriebsmittel in seiner Bauart mit den in der Anlage zu dieser Bescheinigung festgelegten Ausführungen übereinstimmt und daß die vorgeschriebenen Stückproben entnommen werden.
- (9) Das elektrische Betriebsmittel darf mit dem hier abgedruckten gemeinschaftlichen Unterscheidungszeichen gemäß Anhang II der Richtlinie des Rates vom 6. Februar 1979 (79/196/EWG) gekennzeichnet werden.

Im Auftrag

J. Schebsdat
Dr.-Ing. Schebsdat
Regierungsdirektor



Braunschweig, 12.01.1993

Prüfbescheinigungen ohne Unterschrift und ohne Dienststempel haben keine Gültigkeit.
Die Bescheinigungen dürfen nur unverändert weiterverbreitet werden.
Auszüge oder Änderungen bedürfen der Genehmigung der Physikalisch-Technischen Bundesanstalt, Bundesallee 100, Postfach 33 45, D-3300 Braunschweig.

V 13-755 32007-1 90

Physikalisch-Technische Bundesanstalt

ANLAGE

zur Konformitätsbescheinigung PTB Nr. Ex-92.C.2146

Der Meßumformer SITRANS P Typ 7MF4***-****-1B+* dient in seinen verschiedenen Ausführungen zur Messung von Druck, Absolutdruck, Differenzdruck, Durchfluß oder Füllstand von Flüssigkeiten, Gasen oder Dämpfen.

Die höchstzulässige Umgebungstemperatur in Abhängigkeit von der Temperaturklasse ist der folgenden Tabelle zu entnehmen:

Temperaturklasse	Umgebungstemperatur
T6	60°C
T5	75°C
T4	85°C

Elektrische Daten

Hilfsenergie-/Ausgangssignalstromkreis (Anschluß : +, -) in Zündschutzart Eigensicherheit EEx ia IIC nur zum Anschluß an bescheinigte eigensichere Stromkreise mit folgenden Höchstwerten: $U_0 = 30$ V, $I_k = 100$ mA, $P = 750$ mW

wirksame innere Induktivität $L_i = 0,6$ mH
wirksame innere Kapazität $C_i = 6$ nF

Kontrollanzeigerstromkreis (Anschluß: Testbuchsen)

in Zündschutzart Eigensicherheit EEx ia IIC nur zum Anschluß an erdfreie Anzeiger oder Prüfgeräte ohne eigene Stromversorgung (Batterie, Netz) und ohne Fremdstromkreise
Höchstwerte: $U_0 = 30$ V, $I_k = 100$ mA

höchstzulässige äußere Induktivität $L_a = 0,6$ mH
höchstzulässige äußere Kapazität $C_a = 7$ nF

Prüfungsunterlagen

unterschieden am:

1. Beschreibung (15 Blatt) 07.09.1992
2. Zeichnung Nr. C73451-A400-X100*-26
Blatt 0, 1, 4, 6 12.10.1992
Blatt 2, 3, 5, 7-15 07.09.1992

Im Auftrag

J. Schebsdat
Dr.-Ing. Schebsdat
Regierungsdirektor



Braunschweig, 12.01.1993

Blatt 1/1

V 13-755 320 11-7-88

Siemens AG
Automation
Process Automation,
Test and Measurement Systems
D-76181 Karlsruhe

Siemens Aktiengesellschaft

© Siemens AG 1993 All rights reserved

Order No. C73000-B5676-C71-3
Available from: AUT 3 PAZ
Printed in the Federal Republic of Germany
AG 0995 1.0 OR 28 En



Progress
in Automation.
Siemens